

Recommended PBF-100 External Plumbing Assembly

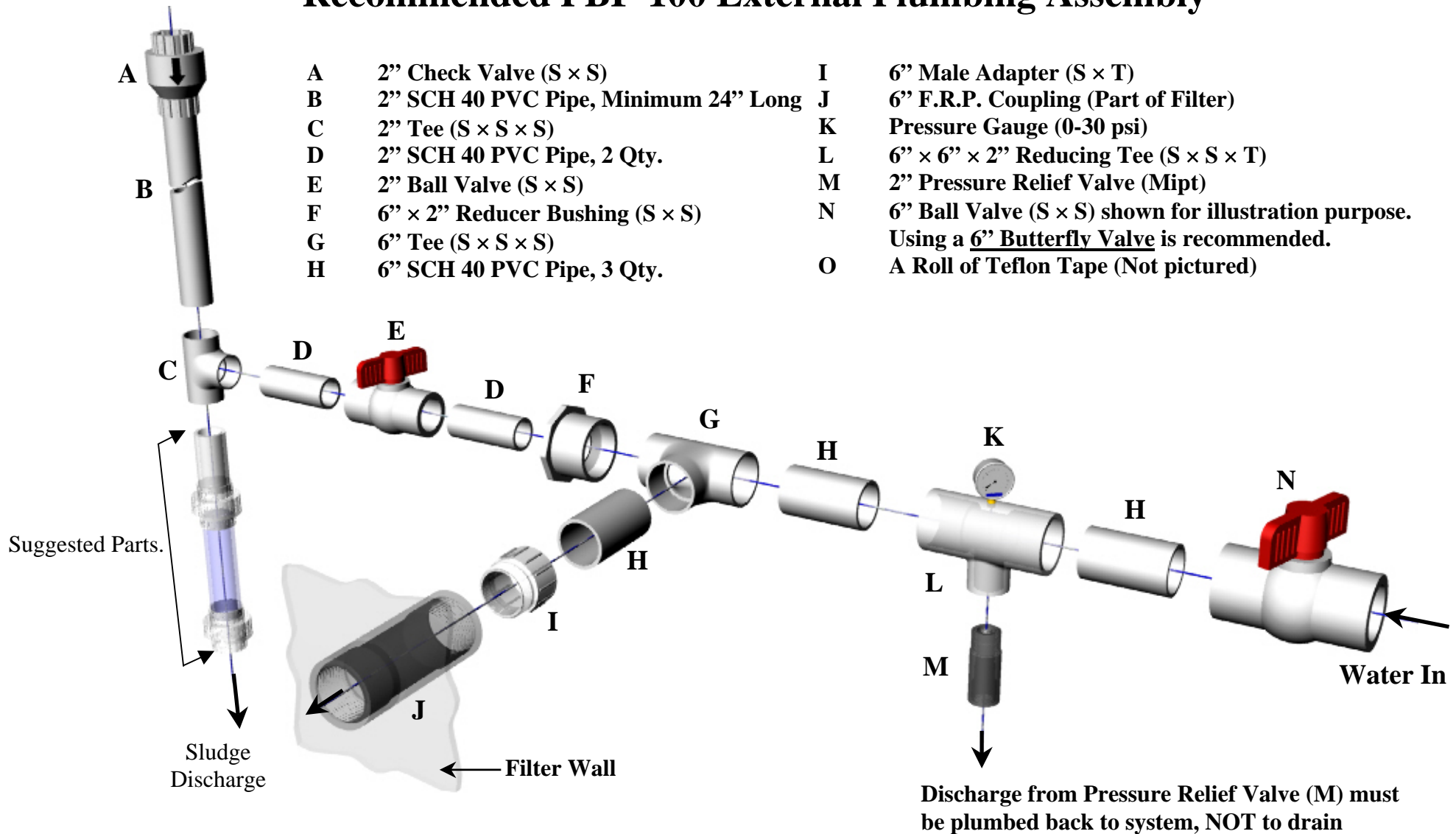

1. All threaded fittings must be Teflon taped (multiple wraps) or treated with PVC compatible Teflon thread sealant.
2. One to two turns beyond finger tight is all that is required to make a sound plastic threaded connection.
3. Pressure Relief Valve (M) should be pre-set to pop-off at approximately 20 psi. Discharge from Pressure Relief Valve (M) should be plumbed back to the system and NOT to waste.
4. Pressure Relief Valve (M) is constructed of SCH 80 PVC and Stainless Steel, care should be taken when using in brackish and saltwater environments.