

HPPG-50 SPECIFICATIONS

An air flow rotameter (backwash frequency control) is required to regulate the air flow from the air pump. The air injected into the system regulates the backwash frequency. Sludge is manually drained periodically, minimizing water loss.

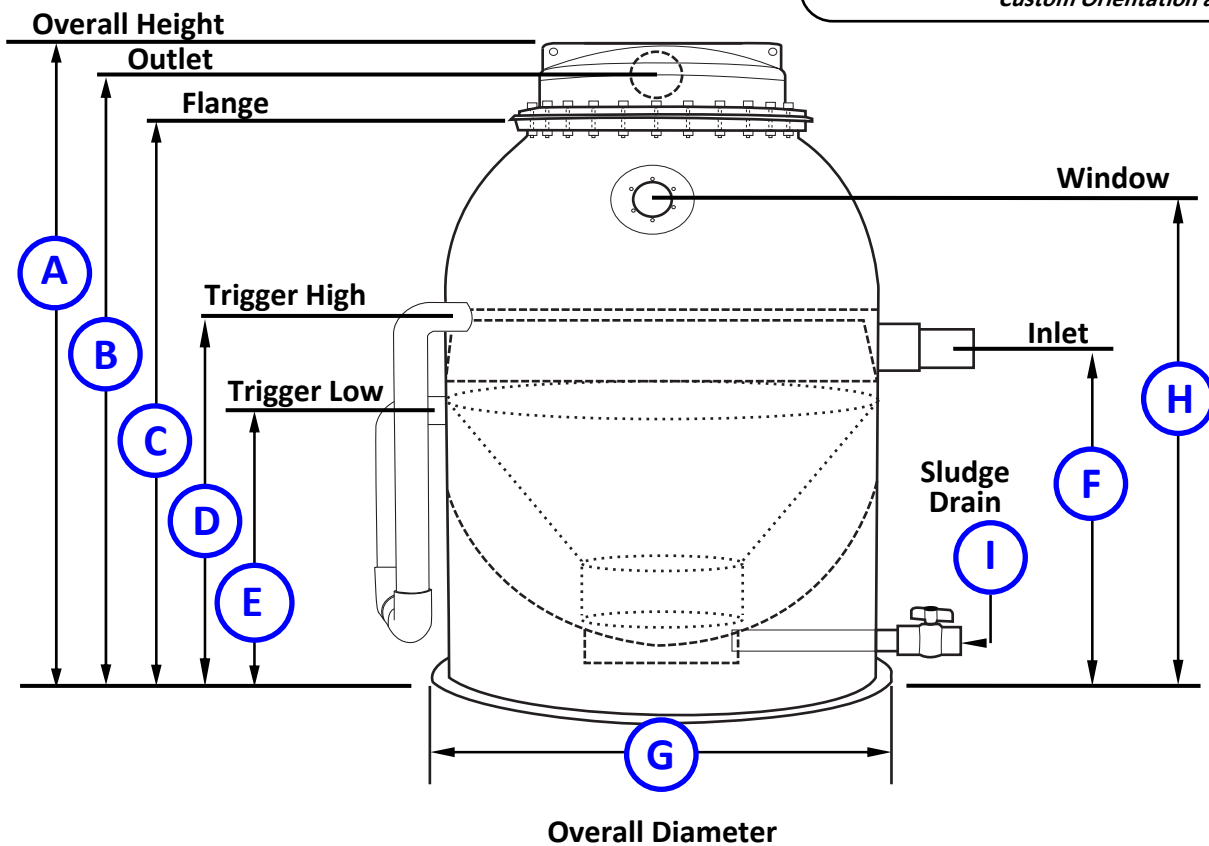
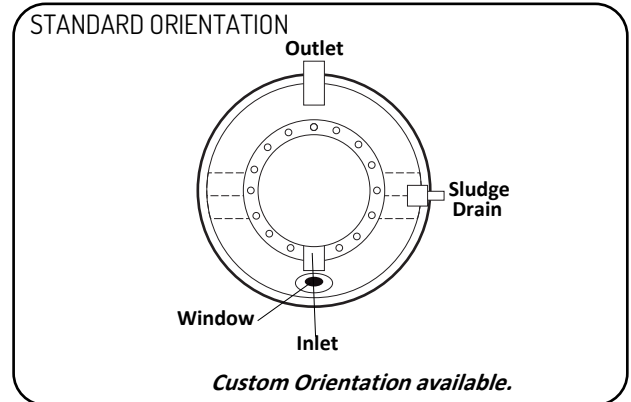

A	114"
B	103"
C	94"
D	49"
E	39.5"
F	61"
G	85"
H	77"
I	5.75"

Max Flow Rate	750 gpm
Ft ³ of Media	50
Ft ² of Surface Area	20000
Inlet Pipe	8" Flange Fitting
Outlet Pipe	(2x) 8" Flange Fitting
Sludge Drain Valve	2" FIPT
Max Operating Pressure	20 PSI
Shipping Weight	3250 Lbs

Filter shown for Illustrative Purposes only.

Drawing is NOT drawn to scale.