

HPPG-25 SPECIFICATIONS

An air flow rotameter (backwash frequency control) is required to regulate the air flow from the air pump. The air injected into the system regulates the backwash frequency. Sludge is manually drained periodically, minimizing water loss.

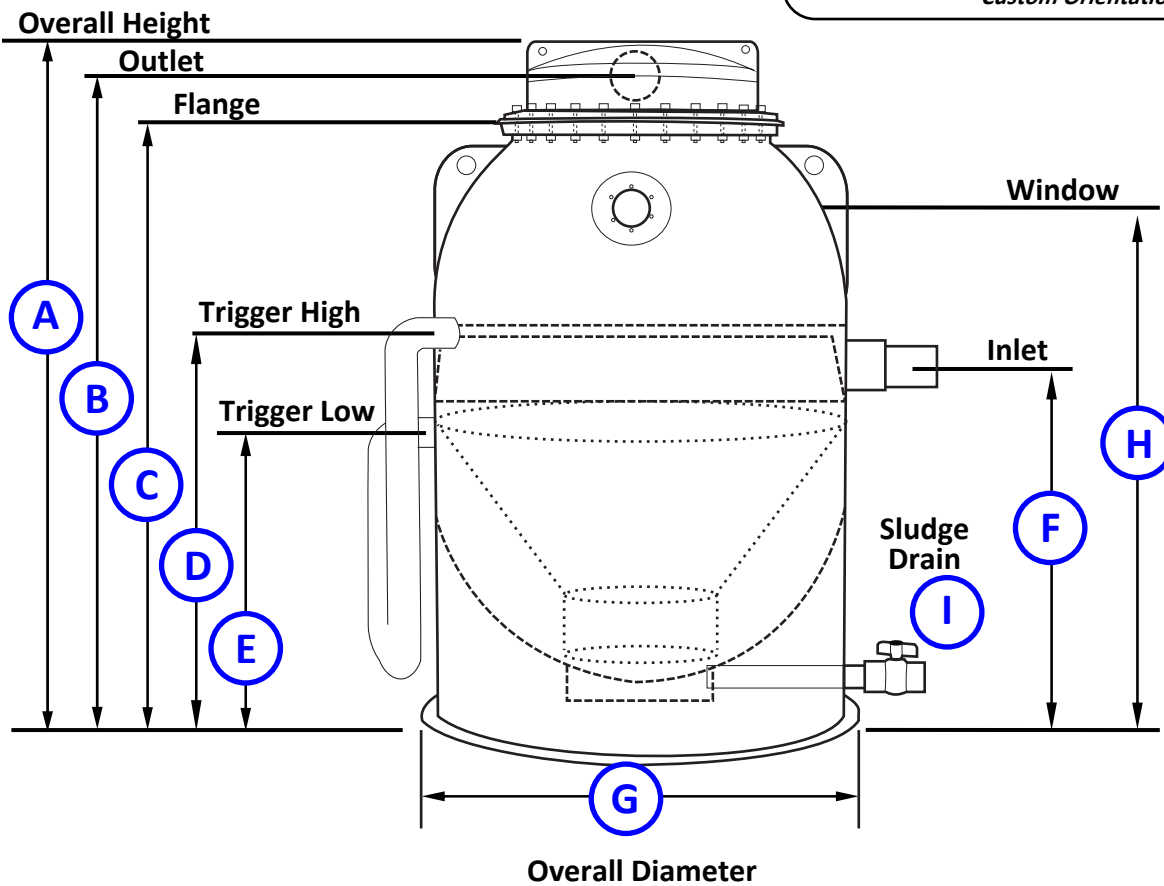
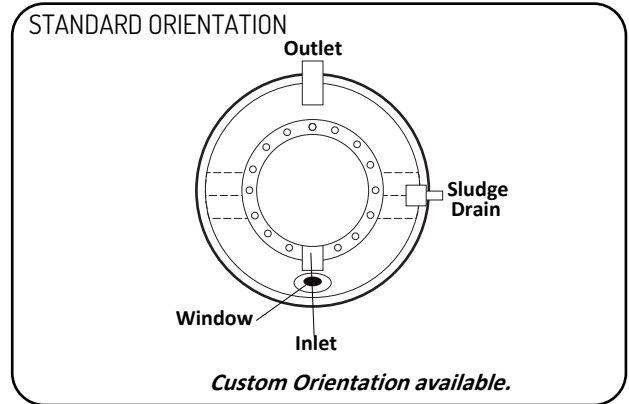

A	104"
B	94.5"
C	87.5"
D	49"
E	39.5"
F	60.25"
G	59"
H	68.5"
I	3.5"

Max Flow Rate	375 gpm
Ft ³ of Media	25
Ft ² of Surface Area	10000
Outlet Pipe	(2x) 6" FIPT
Inlet Pipe	6" FIPT
Sludge Drain Valve	1.5" FIPT
Max Operating Pressure	20 PSI
Shipping Weight	1700 Lbs

Filter shown for illustrative purposes only.

Drawing is NOT drawn to scale.